

# 2024 Doctoral Education Conference

## Exhibit & Sponsorship Prospectus



January 18-20, 2024  
Naples Grande Beach Resort  
Naples, FL

Visit [www.aacnnursing.org/doctoral-conference](http://www.aacnnursing.org/doctoral-conference) to learn more.

Dear Exhibitor,

Showcase your innovative products and services at this year's 2024 Doctoral Education Conference, January 18-20, 2024, in Naples, FL. This event invites deans, directors, and faculty from nursing schools nationwide to explore innovative strategies and opportunities in doctoral nursing education.

Our customizable sponsorship opportunities allow you to amp up your presence further and complement your unique audience engagement strategy. Utilize our in-person conference platform to raise brand awareness, attract new business, and connect with those leading the change in nursing education, health, and health care!

Submit your application [here](#) or email Kate Waggoner, [kwaggoner@aacnnursing.org](mailto:kwaggoner@aacnnursing.org) for additional information.

See you in Lake Buena Vista, FL!

## BENEFITS OF EXHIBTING

- 1 Exclusive access to academic nursing leaders from AACN member schools.
- 2 Gain insights into current issues, industry trends, and challenges your customers are facing.
- 3 Reach an audience with buying power.
- 4 Network and connect with customers face-to-face at your booth.
- 5 Promote brand awareness to generate sales leads and new customers.

## WHO SHOULD EXHIBIT?

Companies and Organizations offering services and products in the areas of:

- Analytical Services
- Background/Drug Testing
- Certification
- Clinical Placement
- Curriculum Management
- Consulting Services
- Education Technology
- Health & Wellness
- Medical Supplies
- Nursing Apparel
- Online Testing
- Professional Association
- Publishing
- Research
- Simulation Technology
- Software/Information Systems
- Student Admission & Application Services



# WHAT TO EXPECT ONSITE...

- One 6-foot skirted table within an approximate 6 ft x 6 ft space
- Carpeted exhibit space
- Two chairs
- Booth identification sign
- Wastebasket
- Up to three staff badges
- Access to meal functions
- Access to mailing addresses of event registrants

**\$3,750**



# ATTENDEE DEMOGRAPHICS

Who They Are and Where They Are From:

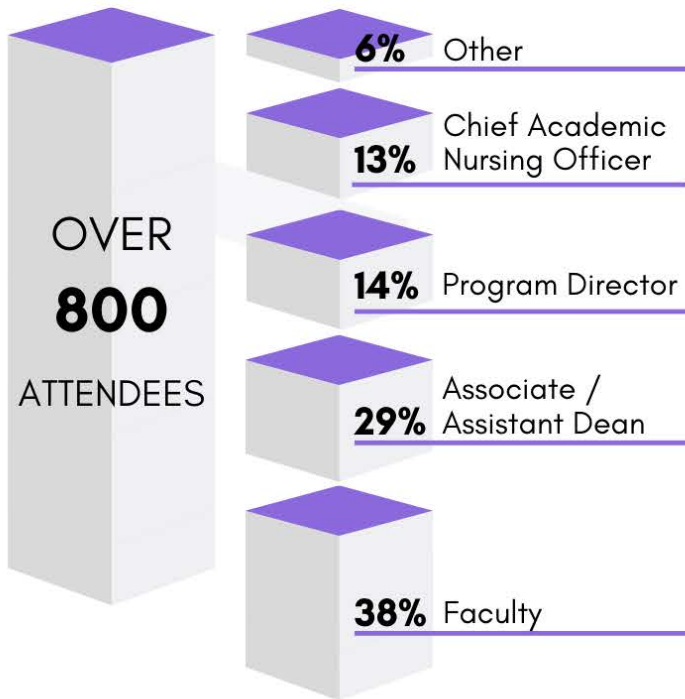

Academic Health Center

**49.6%**

Public School

**23.7%**

Small School

**20.1%**

Private School

**6.6%**

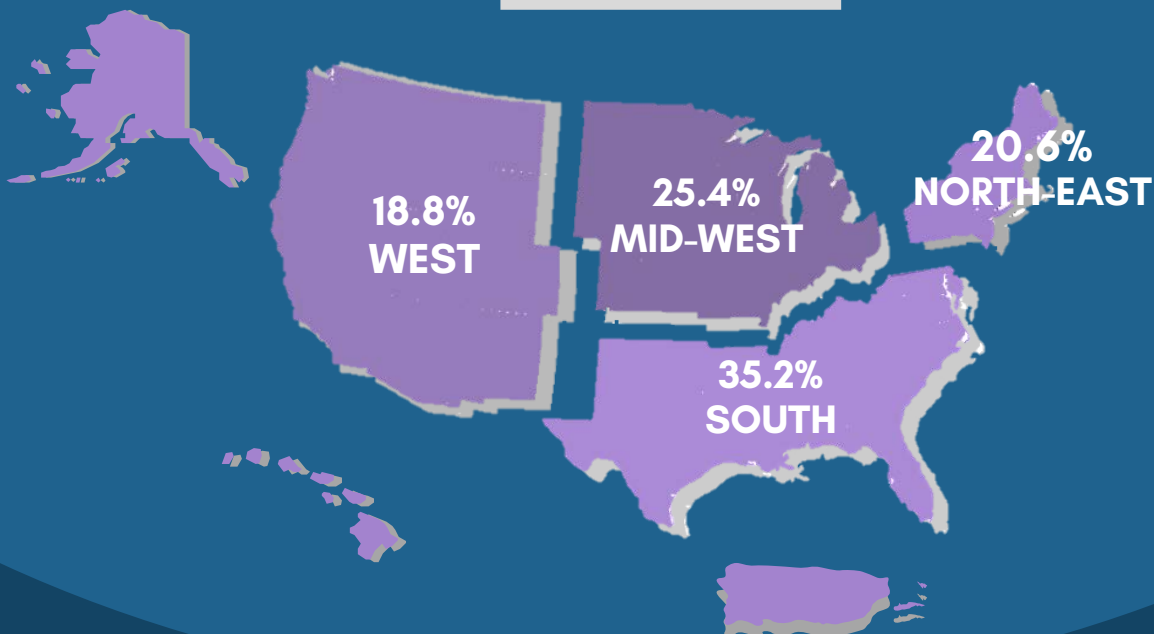

# SET UP

Thursday, January 18

9:00 a.m.-1:00 p.m.

# TEAR DOWN

Friday, January 19

1:30-4:30 p.m.

# SHOWCASE HOURS

Thursday, January 18

1:00-7:00 p.m.

Friday, January 19

8:30 a.m.-1:30 p.m.

*Note: The exhibit hours and floorplan are subject to change.*

## EXHIBITOR SHOWCASE FLOORPLAN

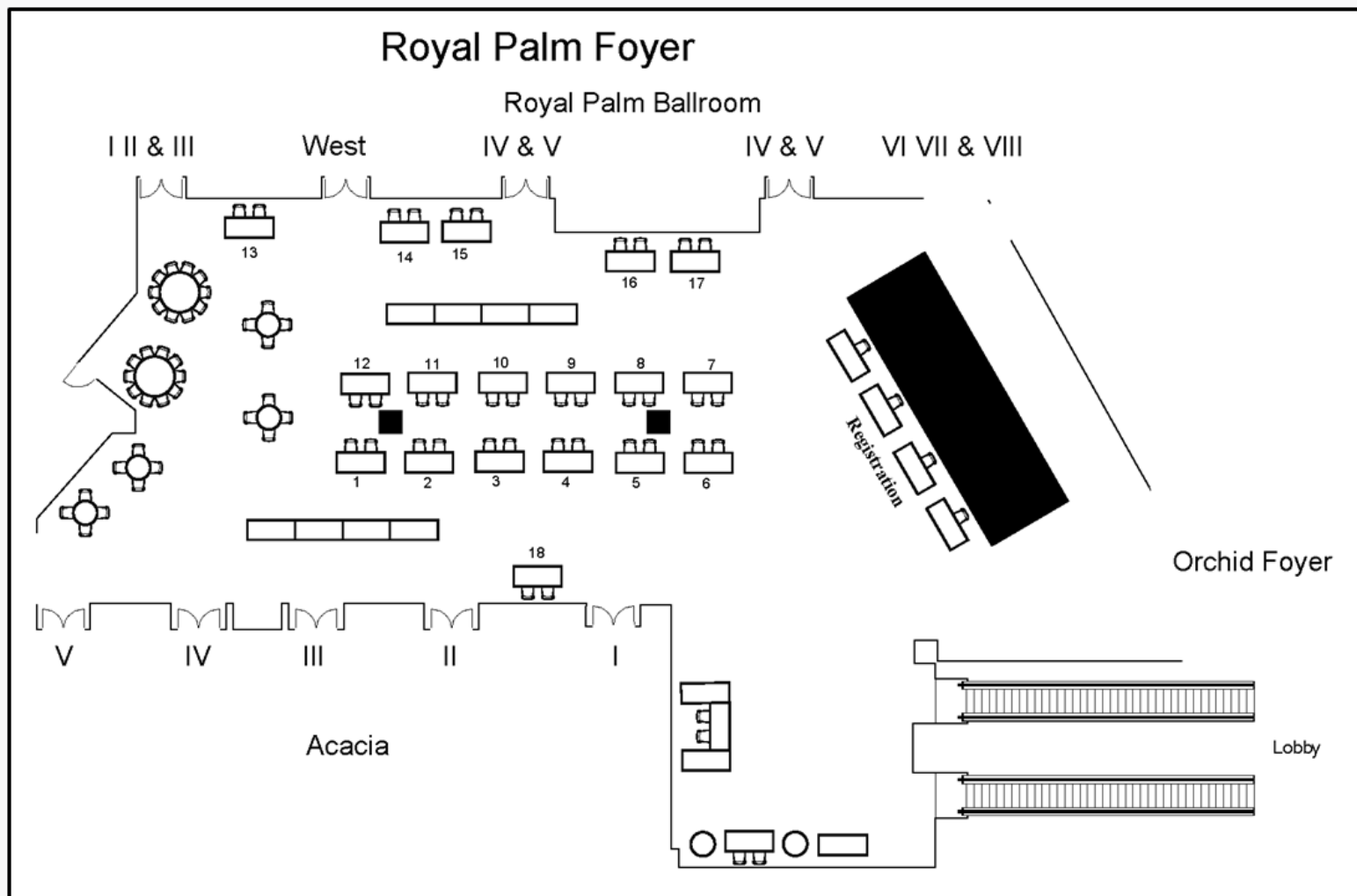

## BOOTH SELECTION

Exhibit booths will be reserved on a first-come, first-serve basis.

Once your payment has been received, a member of the AACN conference team will provide you access to the booth selection and materials forms.

# SPONSORSHIP OPPORTUNITIES

## Opening Plenary

\$6,000

Your company is acknowledged as a supporter of the opening plenary. Plenary speakers feature industry experts and agents of change; they are highly rated and very well attended.

## Closing Plenary

\$6,000

Your company is acknowledged as a supporter of the closing plenary. Plenary speakers feature industry experts and agents of change; they are highly rated and very well attended.



## Coffee/Refreshment Break

\$2,500

Be the reason attendees are awake and smiling. Sponsoring the coffee break means they will have you to thank. You may provide branded water bottles at the water station.

*(Limited Availability)*

## Solution Circle

\$5,000

Position yourself as a strategic partner to meet our members needs. Host a 60-minute educational session to connect with conference participants in a collaborative format while examining current challenges in the field of academic nursing. Solution Circle Hosts will be listed on the conference schedule. Session content must be approved by AACN. *(Limited Availability)*



## Conference Welcome Bag

\$5,500

Be on everyone's mind when each attendee will receive your co-branded bag at the registration desk.

## Welcome Bag Insert

\$1,500

Drive traffic to your booth by advertising in each attendee's conference bag.

*(Limited Availability)*

## Lanyards

\$5,000

Make your company a part of every attendees outfit of the day. Attendees will be wearing lanyards with your logo throughout the entire conference.



# SPONSORSHIP OPPORTUNITIES

CONTINUED

## Pre-Conference Email Blast

\$2,000

Company-provided content will be distributed by AACN via email to all registered conference attendees prior to the conference. Email must be approved by AACN.

*(Limited Availability)*



## Post-Conference Email Blast

\$2,000

Company-provided content will be distributed by AACN via email to all registered conference attendees following the conference. Email must be approved by AACN.

*(Limited Availability)*

## WiFi Partner

\$5,000

This exclusive opportunity allows you to connect with attendees virtually everywhere. Your company name (or abbreviation thereof) will be used by all onsite attendees as the password for internet login.



## Push Notifications in Mobile App

\$1,000

A great way to notify attendees of product launches or other important messaging that you want them to know. Includes 3 custom messages, one per day.

*(Limited Availability)*

# CUSTOM SPONSORSHIP

Have a sponsorship you don't see? Give us a call and let's make it happen! We are ready to help you create a lasting impression that attendees won't be able to stop talking about.

*Email for Pricing.*

Contact Kate Waggoner for more information: [kwaggoner@aacnnursing.org](mailto:kwaggoner@aacnnursing.org).

**REGISTER  
TODAY!**

**REGISTER**

